



POWERING A GREENER TOMORROW

Wind Energy and the Power Network

Manufacturer's Perspective

David Hodson



About us...

13,000 employees worldwide
AUD \$6.7 billion market capitalization
World's 4th largest wind turbine company

Vertically integrated:
manufactures gearboxes, generators, blades & main shaft.

- Blade design in Holland
- Technology development in Germany
- Manufacturing in India & China

SUZLON

S88 Wind Turbine

2.1 MW induction generator

Tower height: 80m

Blade diameter: 88m

Rotation Speed: 15 RPM

Pitch controlled blades

⇒ Controls aerodynamic power

Controlled rotor resistance

⇒ Controls Torque



SUZLON

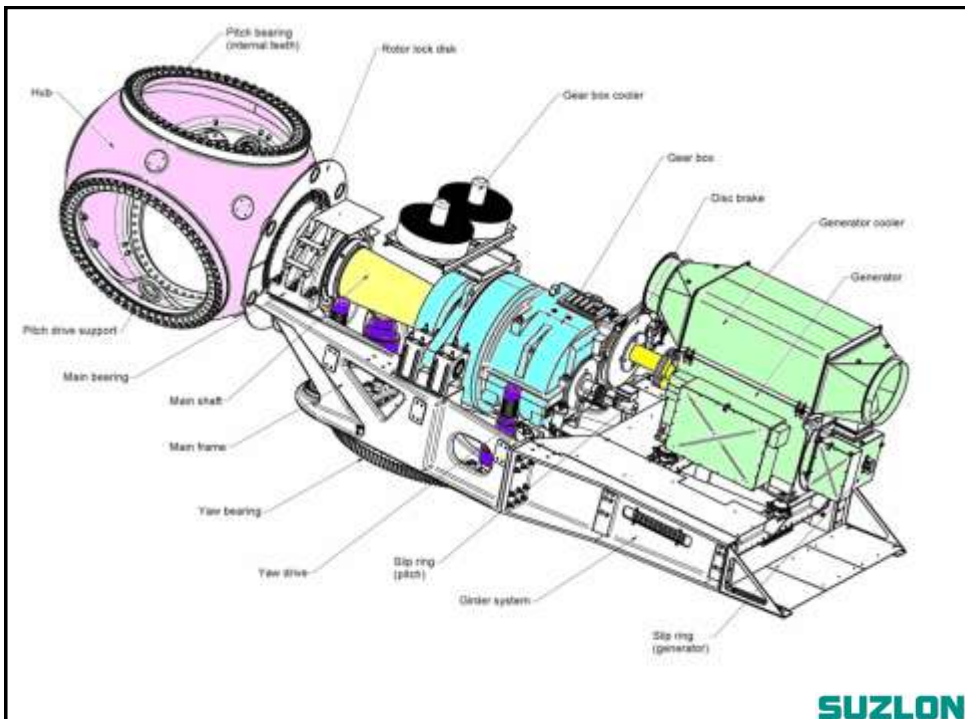

SUZLON

Pitch Control

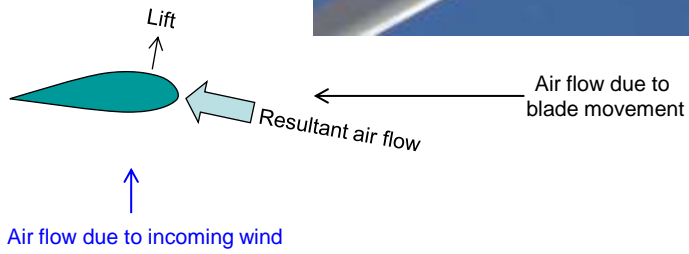

SUZLON

Suzlon Flexislip system

Induction generator torque-speed curve

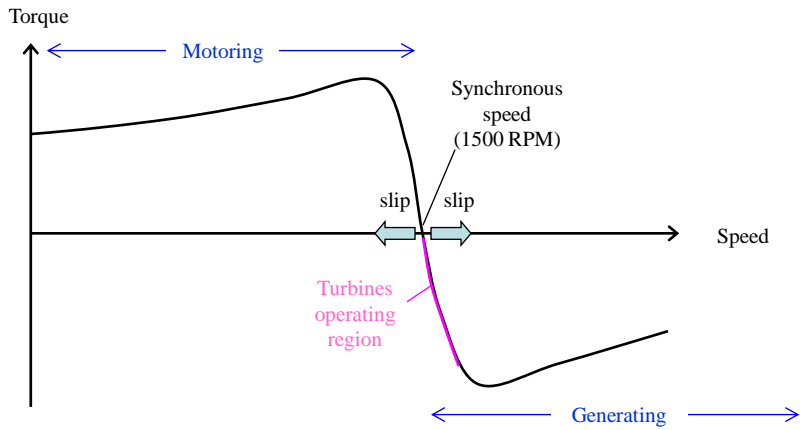

SUZLON

Suzlon Flexislip system

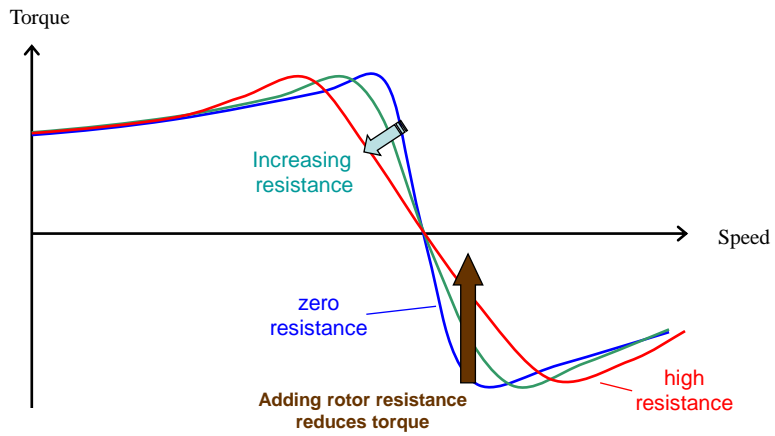

SUZLON

Suzlon Flexislip system

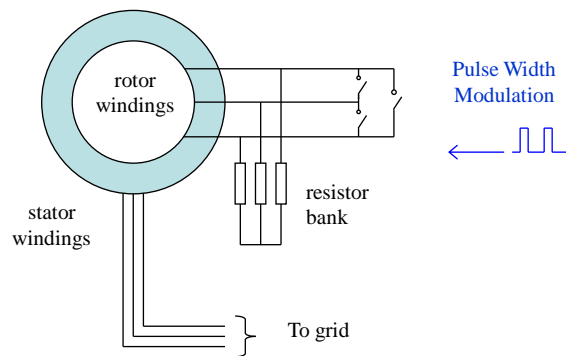

SUZLON

Reactive Power Requirements

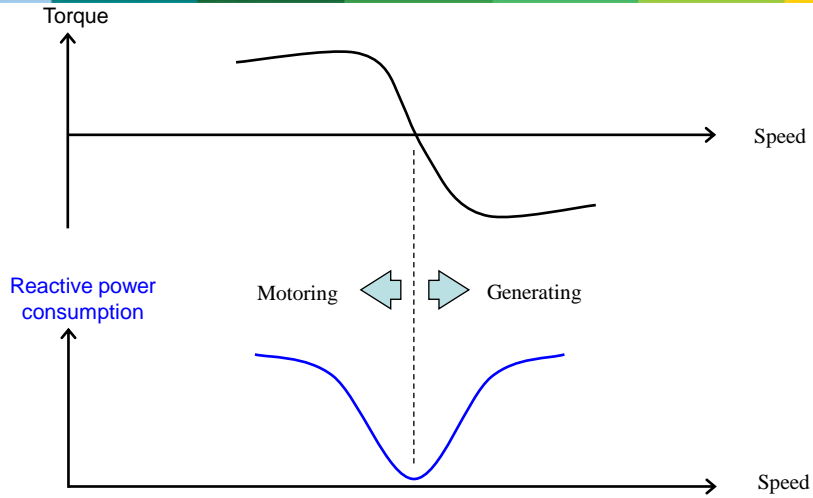

SUZLON

Controlling Reactive Power

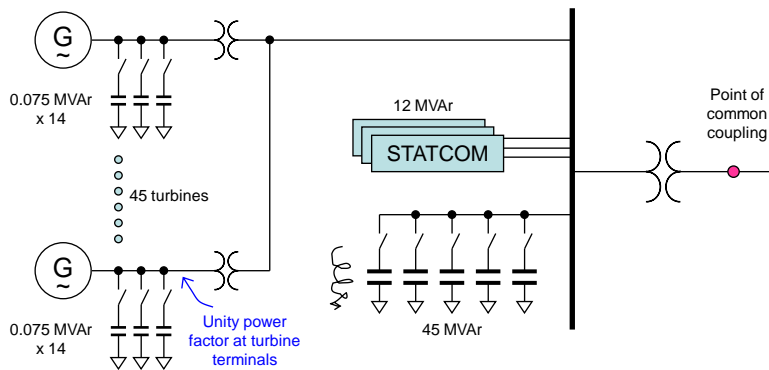

SUZLON

